



# Autobroil™

Model 4-12GT

## Straight Through Conveyor Gas Broiler

Item No: \_\_\_\_\_

AIA FILE NO. / SPEC NO.

CONSULTANT/ CONTRACTOR APPROVAL



Model 4-12GT

The Marshall **Model 4-12GT** is designed for high-volume hamburger or meat filet production, toasting, or cheesemelting. The 1000° metal infrared heat source broils the meat quickly, giving the advantage of speed, plus sealing in juices for better taste.

The **Model 4-12GT** has two 12" broiling belts and two 12" radiant toasting/cheesemelting belts, which allow for different cook speeds and menu flexibility. The food is loaded at the front of the broiler or toaster and is automatically delivered to holding trays at the rear.

All Marshall products are supported by a nationwide service organization and in-house, full-time Customer Support Department. To place an order call:

**1-800-627-8368**

**ETL (US, Canada) & NSF Listed  
FOR COMMERCIAL USE ONLY**

*\*Ask about Marshall's ThermoGlo™ Food Warmers,  
companion High Speed Toasters, and Ventilation Systems*

**Marshall's large capacity, high production hamburger and meat filet broilers. High temperature infrared heat and direct on-conveyor broiling for speed, flavor enhancement and bar marks.**

### FEATURES

- Straight through cooking arrangement - Fully automatic
- Electronic ignition (gas) - Simply use the on/off switch
- Digital microprocessor control for energy load monitoring
- Individual plug-in motors for speed control of each broiler belt
- Independent toaster section for maximum flexibility
- Less removable parts allows for fast and easy clean up
- Energy-saving pilot shut-off system (gas)

### CONSTRUCTION

- Heavy gauge stainless steel solid weld construction
- 3/16" Diameter, heavy-duty stainless steel conveyor rods
- Stainless steel internal gas lines
- Simple conveyor tension adjustment
- Easy to operate computer control panel
- Heavy duty industrial grade heating elements or gas burners

### VOLUME

#### **Hamburger Peak Production:**

Frozen 2 oz Patties 750/hr  
4 oz Patties 450/hr  
Fresh 2 oz. Patties 950/hr  
4 oz. Patties 575/hr

#### **Toaster Peak Production:**

Sub Sandwiches Varies based on size and  
casseroles, nachos, etc. cook time

*(Figures for estimating only. Actual production varies with fat content, surface texture and meat starting temperature.)*

---

### Marshall Air Systems, Inc.

419 Peachtree Drive South • Charlotte, North Carolina 28217 USA • Phone: (704) 525-6230 Fax: (704) 525-6229 • www.marshallair.com



# Autobroil™

Model 4-12GT

Straight Through Conveyor Gas Broiler

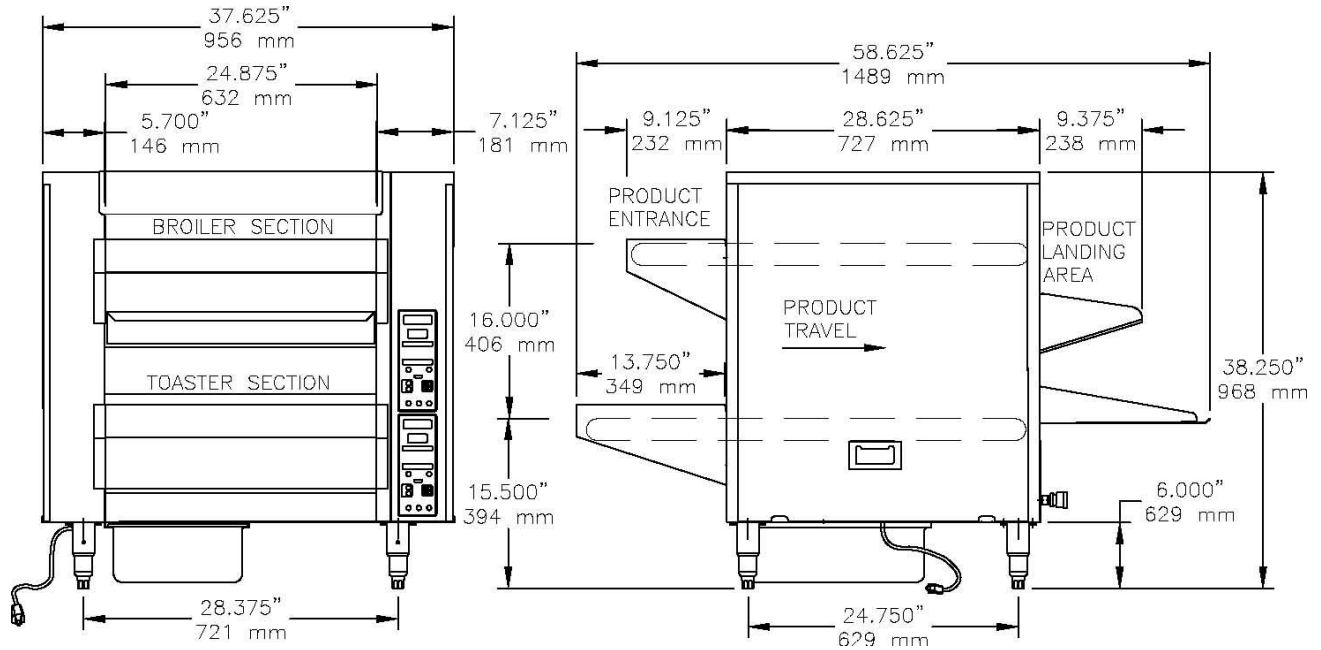

### Overall Dimensions Model 4-12GT

Dimensions:	Height: 38.25" 968 mm	Width: 37.625" 956 mm	Depth: 58.625" 1489 mm	
Shipping Information:	Weight: Net 550 lbs. 250 kg	Ship Wt: 625 lbs. 284 kg	Freight (USA) NMFC Class 85	Ship Cubes: 5 cubic ft. 2.2 cubic meters
Electrical Wiring:	208V/60Hz/1 ph 45 Amps / 9.36 kw L1, L2, G		Other voltage configurations available --Contact Factory--	
Gas Supply:	101,000 BTUH – LP or Nat. 3/4" NPT Supply			
Options:	Autocat™ - Catalytic Converter Companion Ventilation System Heavy duty stainless steel stand with casters Complete spare parts kit 36" or 72" Flexible gas line with quick disconnect and restraining device International voltage available			

### Marshall Air Systems, Inc.

419 Peachtree Drive South • Charlotte, North Carolina 28217 USA • Phone: (704) 525-6230 Fax: (704) 525-6229 • www.marshallair.com