



Autobroil™

Model 713BG

Straight Through Conveyor Gas Broiler

Item No: _____

AIA FILE NO. / SPEC NO.

CONSULTANT/ CONTRACTOR APPROVAL



Model 713BG

The Marshall **Model 713BG** is designed for intense high volume usage. The hybrid burner technology easily broils a variety of gourmet meat items, such as ½-lb. burgers, chicken filets, steaks and seafood, sealing in juices for better taste.

The **Model 713BG** has two broiling belts, one 7" and one 13", which allow for different cook speeds and menu flexibility. The straight-through configuration is designed so that meat items are loaded at the front of the broiler directly on the belt or in pans, and automatically delivered to holding trays at the rear.

All Marshall products are supported by a nationwide service organization and in-house, full-time Customer Support Department. To place an order call:

1-800-627-8368

**ETL (US, Canada) & NSF Listed
FOR COMMERCIAL USE ONLY**

**Ask about Marshall's ThermoGlo™ Food Warmers,
companion High Speed Toasters, and Ventilation Systems*

Marshall's large capacity, high production hamburger and specialty meat broiler. Hybrid burner technology and direct conveyor broiling for speed, flavor enhancement, and bar marks.

FEATURES

- Straight through cooking arrangement - Fully automatic
- Electronic ignition (gas) - Simply use the on/off switch
- Autoloader™ dispenses product onto cooking belt automatically
- Individual plug-in motors for speed control of each broiler belt
- Modulating gas system monitors cooking chamber temperatures for consistent cooking
- Six-button control allows setup of three different cooking times per belt
- Integrated food probe and logging
- Sleek design allows for fast and easy clean-up

CONSTRUCTION

- Heavy gauge stainless steel solid weld frame construction
- 3/16" diameter, heavy-duty stainless steel conveyor rods
- Stainless steel internal gas lines (gas models)
- Simple conveyor tension adjustment
- Easy to operate computer control panel
- Heavy duty industrial grade heating elements or gas burners

VOLUME

Hamburger Peak Production:

Frozen 2 oz Patties 725/hr.
4 oz Patties 450/hr.
Fresh 2 oz Patties 950/hr.
4 oz Patties 575/hr.
8 oz Patties 310/hr.

(Figures for estimating only. Actual production varies with fat content, surface texture and meat starting temperature.)

Marshall Air Systems, Inc.

419 Peachtree Drive South • Charlotte, North Carolina 28217 USA • Phone: (704) 525-6230 Fax: (704) 525-6229 • www.marshallair.com



Autobroil™

Model 713BG

Straight Through Conveyor Gas Broiler

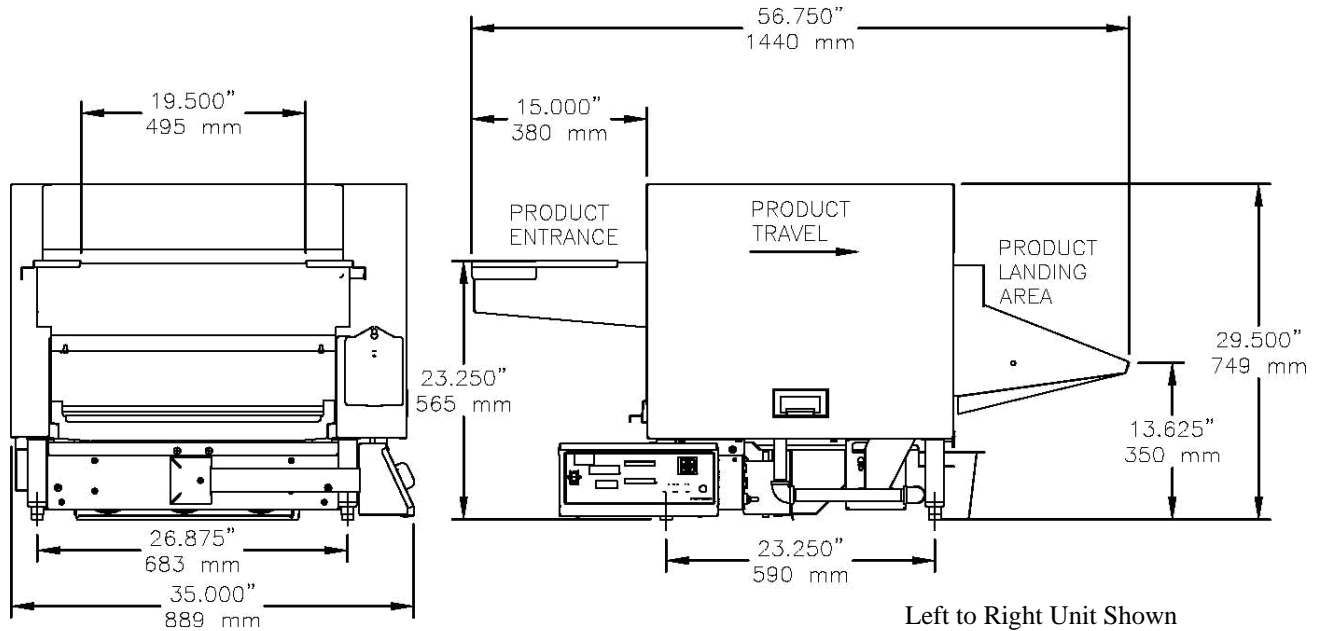

Overall Dimensions Model 713BG

Dimensions:	Height: 29.500" 749mm	Width: 35.000" 899mm	Depth: 56.750" 1440mm	
Shipping Information:	Weight: Net 500 lbs. 235 kg	Ship Wt: 549 lbs. 257 kg	Freight (USA) NMFC 27520 Class 85	Ship Cubes: 57 cubic ft. 1.62 cubic meters
Electrical Wiring:	120V/ 60Hz/1 ph 2 amps / 0.24 kw NEMA 5-20 Plug			
Gas Supply:	146,000 BTUH @ 100% High Fire 3/4" NPT Supply (5.0" W.C.)			
Options:	Autocat™ - Catalytic Converter Companion Ventilation System Heavy-duty stainless steel stand with casters Complete spare parts supply kit 48" Flexible gas line with quick disconnect and restraining devise (<i>gas</i>) Companion Cheesemelter International voltage available Food probe			

Marshall Air Systems, Inc.

419 Peachtree Drive South • Charlotte, North Carolina 28217 USA • Phone: (704) 525-6230 Fax: (704) 525-6229 • www.marshallair.com