



ThermoGlo™

Model BW4B Slicer Warmer

Item No: _____

AIA FILE NO./ SPEC NO.

CONSULTANT/ CONTRACTOR APPROVAL



Model BW4B
(Slicer not included)

The Marshall **Model BW4B** Slicer Warmer features patented ThermoGlo™ heating technology. Heat radiates from every square inch of the upper and lower flat plate surfaces maintaining uniform holding temperature and improved moisture retention for up to 45 minutes. The upper heat plate centers over the meat while the lower plate provides heat to the sliced meat as it falls on to the slicer landing area.

Marshall's ThermoGlo™ technology replaces heat lamps and lamp sockets with a robust, unbreakable design that is easy to clean. The **Model BW4B** is designed to be counter-top mounted. The top heater arm is adjustable to accommodate selected models of either a Globe or Hobart slicer. The self-centering top section swivels with a light touch of the handle allowing easy access to the slicer for adding and removing product and also cleaning.

All Marshall products are supported by a nationwide service organization and in-house, full-time Customer Support Department. To place an order, call your approved Kitchen Equipment Supplier.

Marshall's Slicer Warmer features patented ThermoGlo™ technology designed to solve demanding food warming and holding requirements.

FEATURES

- Upper and lower heat provides consistent product temperatures
- Flat heater surface allows for easy wipe-clean maintenance
- Top portion swivels to allow for easier access
- Food stays "presentation ready" longer
- Unit is designed to mount on a countertop
- No glass bulbs or ceramic heaters

CONSTRUCTION

- Heavy gauge stainless steel
- Designed with a flat unbreakable heat radiating metal face encased in stainless steel housing

ETL (US & Canada) & NSF Listed FOR COMMERCIAL USE ONLY

**Ask about Marshall's companion High Speed Toasters, Conveyor Broilers and Ventilation Systems.*

Marshall Air Systems, Inc.

419 Peachtree Drive South • Charlotte, North Carolina 28217 USA • Phone: (704) 525-6230 Fax: (704) 525-6229 • www.marshallair.com

Printed in U.S.A. © Marshall Air Systems, Inc. 2007 All rights reserved.

Marshall's commitment to quality and product improvement may change specifications from time to time.

Rev09302011



ThermoGlo™

Model BW4B Slicer Warmer

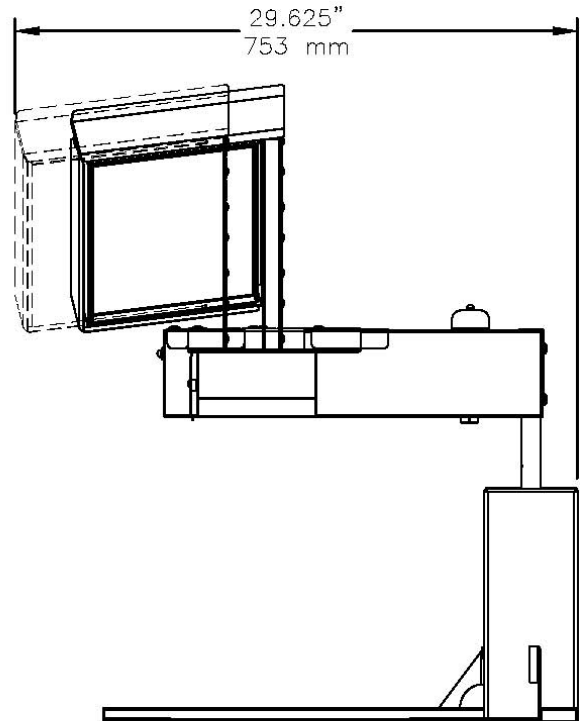
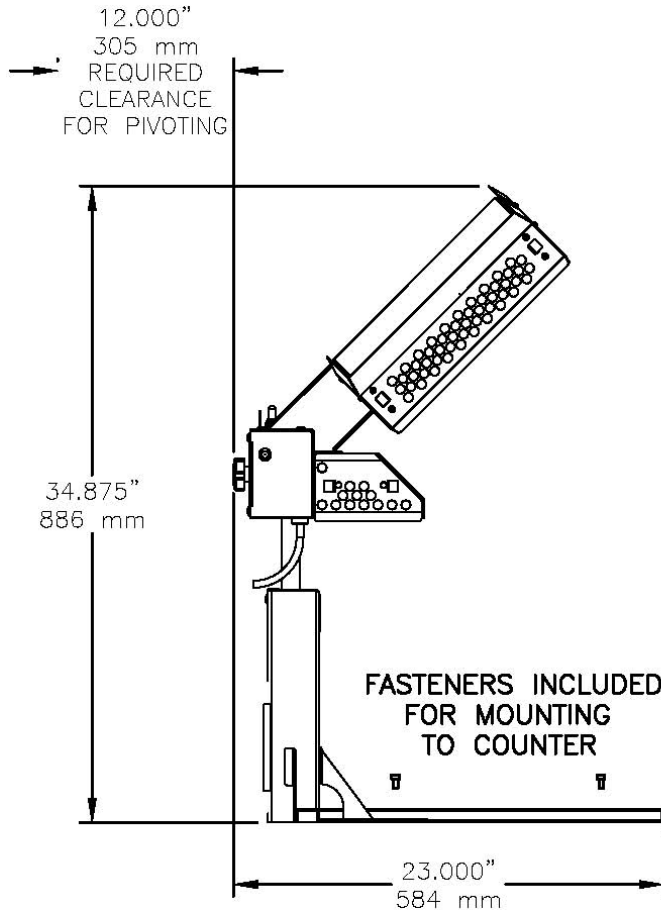

BW4B Shown without Slicer

Overall Dimensions Model BW4B

Dimensions:	Height: 34.875" (886mm)	Width: 29.625" (753mm)	Depth: 23.000" (584mm)
-------------	----------------------------	---------------------------	---------------------------

Shipping Information:	Weight: 36 lbs. (16 kilos)	Ship Wt: 56 lbs. (25.4 kilos)	Freight (USA): NMFC 26100 Class 125	Ship Cubes: 8.2 cubic ft. 0.23 cubic meters
-----------------------	-------------------------------	----------------------------------	---	---

Electrical Wiring:	120V/60Hz/1ph 12.1 amps/ 1.5 kw NEMA 5-15 Plug 8 ft. cord
--------------------	---

Options: Configuration available to accommodate selected models of Globe or Hobart slicers. Please specify.

Marshall Air Systems, Inc.

419 Peachtree Drive South • Charlotte, North Carolina 28217 USA • Phone: (704) 525-6230 Fax: (704) 525-6229 • www.marshallair.com