



ThermoGlo™

Model CM2A

Fried Foods Dump Station

Item No: _____

AIA FILE NO. / SPEC NO.

CONSULTANT / CONTRACTOR APPROVAL



Model CM2A

Marshall's Model CM2A Fried Foods Dump Station features our ThermoGlo™ heating technology. Heat radiates from every square inch of the upper flat plate heating surface. This eliminates the need to clean intricate calrod, wire and reflector assemblies.

The **Model CM2A** solves all of your fried food holding needs in one unit with the capacity to hold up to six items simultaneously. The layout can be reversed to fit your kitchen lineup. Two pullout catch drawers are located underneath the slotted bottom pan for easy cleaning. Bagged holding area makes food preparation simple.

All Marshall products are supported by a nationwide service organization and an in-house, full-time Customer Support Department. To place an order, call:

1-800-627-8368

Marshall's most versatile Fried Foods Dump Station incorporates ThermoGlo™ technology and can be used for holding and warming a wide variety of food products simultaneously.

FEATURES

- Holds multiple products in one location
- Even heat eliminates hot and cold spots
- Flat surface allows for easy wipe-clean application
- Food stays "presentation ready" longer because exact internal temperatures can be reached faster and maintained longer
- Slotted pan for seasoning product
- Empty bag holder provided
- Illumination is provided by (6) 40W lights.

CONSTRUCTION

- Heavy gauge stainless steel
- Designed and built to custom specifications with heat radiating from the ThermoGlo™ surfaces
- Designed with a flat unbreakable radiating metal face encased in stainless steel housing.

**ETL (US & Canada) & NSF Listed
FOR COMMERCIAL USE ONLY**

**Ask about Marshall's companion High Speed Toasters, Conveyor Broilers and Ventilation Systems.*

Marshall Air Systems, Inc.

419 Peachtree Drive South • Charlotte, North Carolina 28217 USA • Phone: (704) 525-6230 Fax: (704) 525-6229 • www.marshallair.com



ThermoGlo™

Model CM2A

Fried Foods Dump Station

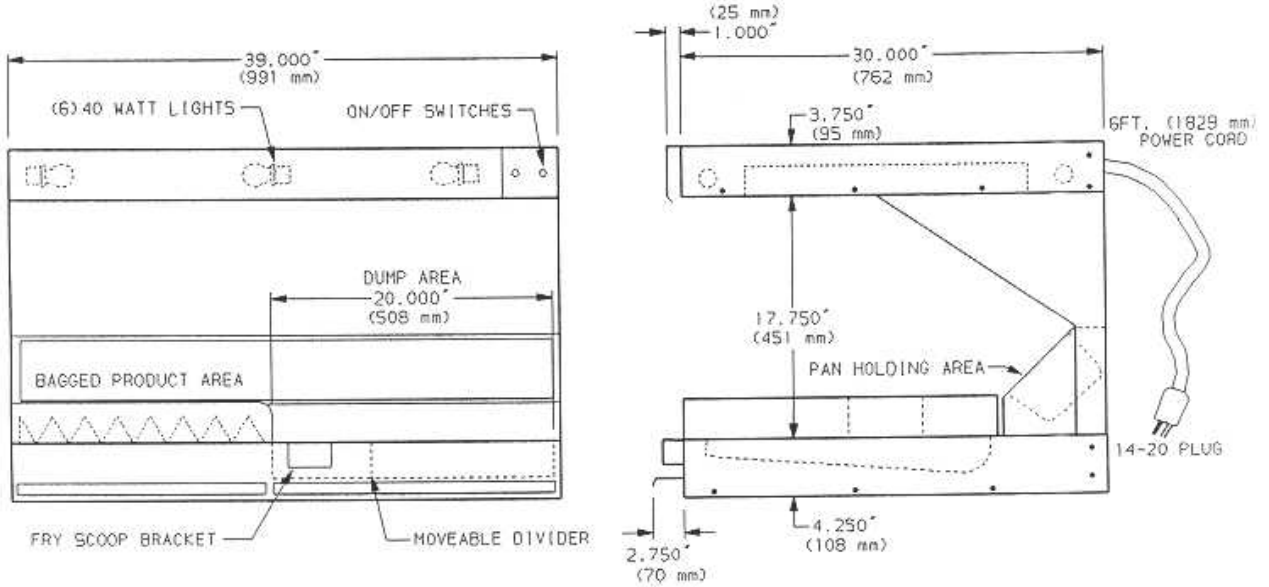

Overall Dimensions Model CM2A

Dimensions:	Height: 25.75" (654 mm)	Width: 39.0" (991 mm)	Depth: 31.0" (787 mm)	
Shipping Information:	Weight: Net 184 lbs. (84 kilos)	Ship Wt: 204 lbs. (93 kilos)	Freight (USA): NMFC Class 100	Ship. Cubes: 42 cubic ft. 1.19 cubic meters
Electrical Wiring:	208V/60Hz/1ph – 12amps 4 Wire w/neutral cord, 14-20P Plug 6 ft. cord			

Marshall Air Systems, Inc.

419 Peachtree Drive South • Charlotte, North Carolina 28217 USA • Phone: (704) 525-6230 Fax: (704) 525-6229 • www.marshallair.com