



# Autobroil™

## Model FR1012BG

### Front Return Conveyor Gas Broiler

Item No: \_\_\_\_\_

AIA FILE NO. / SPEC NO.

CONSULTANT/ CONTRACTOR APPROVAL



Model FR1012BG

Marshall **Model FR1012BG** Gas Broiler is designed for high volume hamburger or meat filet production. The 1000° plus metal infrared heat source broils the meat quickly, giving the advantage of speed, plus sealing in juices for better taste.

The **Model FR1012BG** has dual broiling belts, one 10" and one 12", which allow for different cooking speeds and menu flexibility. Food is loaded at the front of the broiler and automatically delivered to the front heated holding section.

All Marshall products are supported by a nationwide service organization and in-house, full-time Customer Support Department. To place an order call:

**1-800-627-8368**

**ETL (US, Canada) & NSF Listed  
FOR COMMERCIAL USE ONLY**

*\*Ask about Marshall's ThermoGlo™ Food Warmers,  
companion High Speed Toasters, and Ventilation Systems*

**Marshall's largest capacity, high production front return hamburger and meat filet broilers. High temperature infrared heat and direct on-conveyor broiling for speed, flavor enhancement and bar marks.**

#### FEATURES

- Front return cooking arrangement - Fully automatic
- Electronic ignition
- Digital microprocessor control for energy load monitoring
- Individual plug-in motors and speed control selectors for each conveyor belt
- Convenient functional patty/bun assembly area with ThermoGlo™ technology
- Less removable parts allow fast and easy clean up
- Energy- saving pilot
- Circuit breakers for each pair of elements (electric models)

#### CONSTRUCTION

- Heavy gauge stainless steel solid weld frame construction
- 3/16" Diameter, heavy duty stainless steel conveyor rods
- Stainless steel internal gas lines (gas models)
- Simple conveyor tension adjustment
- Easy to operate computer control panel
- Heavy-duty industrial grade heating elements or gas burners

#### VOLUME

##### **Hamburger Peak Production:**

Frozen 2 oz Patties 725/hr.  
4 oz Patties 450/hr.  
Fresh 2 oz Patties 950/hr.  
4 oz Patties 575/hr.  
8 oz Patties 310/hr.

*(Figures for estimating only. Actual production varies with fat content, surface texture and meat starting temperature.)*

---

#### **Marshall Air Systems, Inc.**

419 Peachtree Drive South • Charlotte, North Carolina 28217 USA • Phone: (704) 525-6230 Fax: (704) 525-6229 • www.marshallair.com



# Autobroil™

## Model FR1012BG

### Front Return Conveyor Gas Broiler

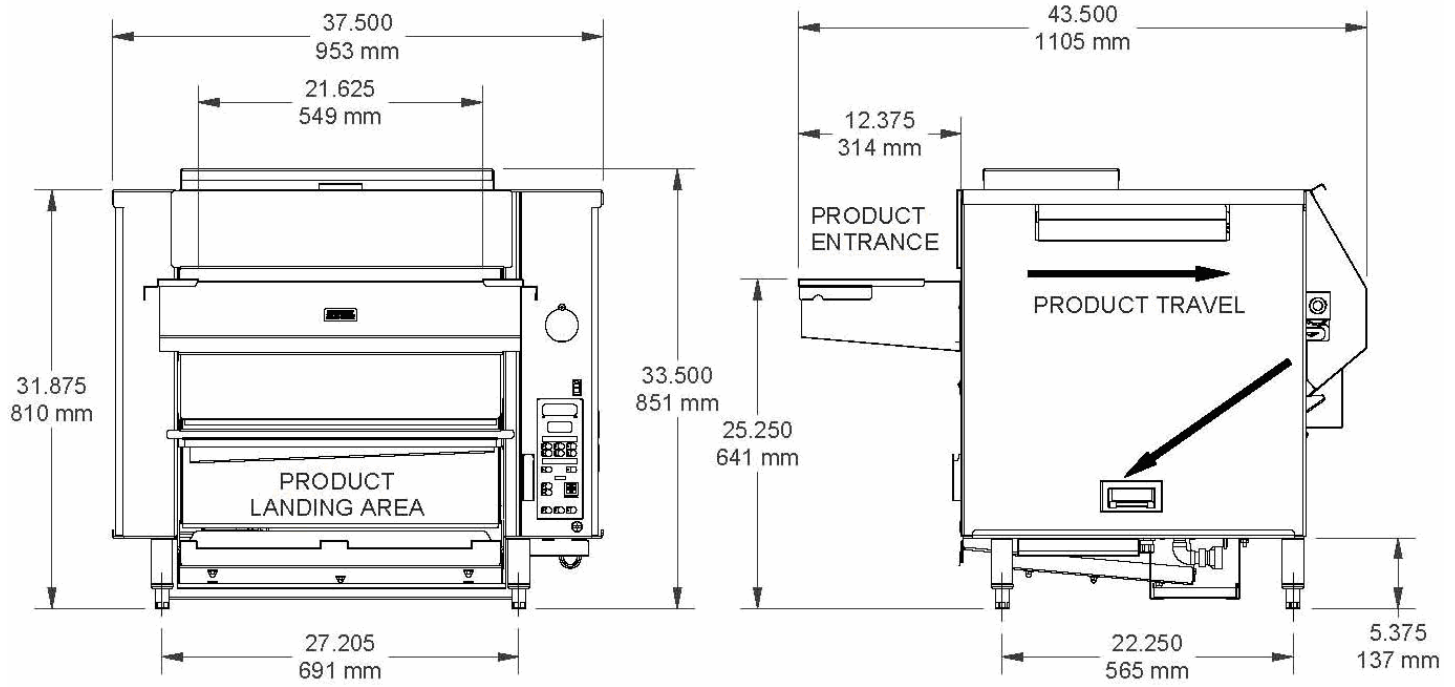

### Overall Dimensions Model FR1012BG

Dimensions:	Height: 33.500" 851mm	Width: 37.500" 953mm	Depth: 43.500" 1105mm		
Shipping Information:	Weight: Net 455 lbs. 207 kilos	Ship Wt: 495 lbs. 225 kilos	Freight (USA) NMFC Class 85	Ship. Cubes: 58.2 cubic ft. 1.65 cubic meters	
Electrical:	120V/60Hz/1 ph 6 amps NEMA				
Gas Supply:	140,000 BTUH – LP or Nat. ¾" NPT Supply				
Options:	Autocat™ - Catalytic Converter Complete spare parts supply kit International voltages Heavy-duty stainless steel stand with casters 36" or 72" Flexible gas line with quick disconnect and restraining device ( <i>gas units</i> )		Autoloader™ - Automatic Loading System Companion Ventilation System Extended Loading Arms Fajita Pan Rack		

### Marshall Air Systems, Inc.

419 Peachtree Drive South • Charlotte, North Carolina 28217 USA • Phone: (704) 525-6230 Fax: (704) 525-6229 • www.marshallair.com