



Autobroil™

Model FR15BG & FR69BG

Front Return Gas Countertop Broilers

Item No: _____

AIA FILE NO. / SPEC NO.

CONSULTANT/ CONTRACTOR APPROVAL



Model FR15BG

The **FR15BG** is designed for high hamburger production. Hamburgers cook directly on the heavy-duty conveyor rods for even cooking and the highly desirable grilling bar marks.

The **FR69BG** can accommodate different menu items that require different cook times. Different weight hamburgers or chicken filets cook directly on two individually controlled conveyors.

The **FR15BG** has one 15" belt and is designed for single menu items. The **FR69BG** has two belts, one 6" and one 9", and is designed to cook different size hamburgers or other meat file items.

All Marshall products are supported by a nationwide service organization and an in-house, full service Customer Support Department. To place an order call:

1-800-627-8368

**ETL (US, Canada) & NSF Listed
FOR COMMERCIAL USE ONLY**

High production gas broilers for hamburgers of different sizes and other compatible food items such as chicken and meat filets. Direct on-conveyor broiler produces appealing bar marks and enhances flavor.

FEATURES

- Front return cooking arrangement – Fully automatic
- Compact and versatile size - Fits on countertop
- Electronic ignition – Simply use the on/off switch
- Digital microprocessor control for energy load monitoring.
- Energy-saving pilot shut-off system.
- Individual plug-in motors for speed control of each broiler belt
- Convenient and functional patty/bun assembly area with ThermoGlo™ technology

CONSTRUCTION

- Heavy gauge stainless steel solid weld frame construction
- 3/16" diameter, heavy-duty stainless steel conveyor rods
- Stainless steel internal gas lines (gas models)
- Simple conveyor tension adjustment
- Easy to operate computer control panel
- Heavy duty industrial grade heating elements or gas burners

VOLUME

Hamburger Peak Production:

Frozen 2 oz. patties 440/hr.

4 oz. patties 240/hr.

Fresh 2 oz. patties 550/hr.

4 oz. patties 300/hr.

(Figures for estimating only. Actual production varies with fat content, surface texture and meat starting temperature.)

**Ask about Marshall's ThermoGlo™ Food Warmers, companion High Speed Toasters, and Ventilation Systems*

Marshall Air Systems, Inc.

419 Peachtree Drive South • Charlotte, North Carolina 28217 USA • Phone: (704) 525-6230 Fax: (704) 525-6229 • www.marshallair.com



Autobroil™

Model FR15BG & FR69BG

Front Return Gas Countertop Broilers

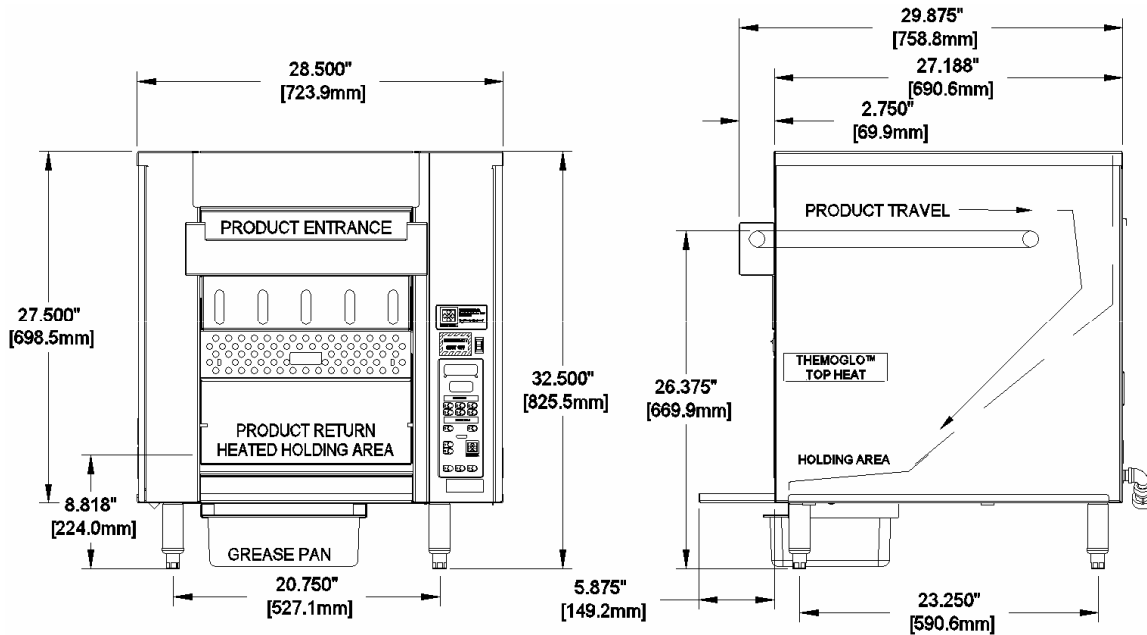

Overall Dimensions FR15BG & FR69BG

Dimensions:	Height: 32.5" 826 mm	Width: 28.5" 724 mm	Depth: 29.875" 759 mm	
Shipping Information:	Weight: Net 270 lbs. 123 kilos	Ship Wt: 315 lbs. 143 kilos	NMFC (Freight USA): Class 85	Ship Cubes: 35.3 cubic ft. 1.0 cubic meters
Electrical: Wiring:	120V/60HZ/1ph-7 amps Plug-in, Standard wall receptacle, 120V	or	240V/50HZ/1 ph-4 amps 240V without plug (L1, N, G)	
Gas Supply:	Liquid propane 61,000 BTUH	or	Natural gas 61,000 BTUH	
Options:	Companion Ventilation System Heavy duty stainless steel stand with casters Complete spare parts supply kit 36" or 72" flexible gas line with quick disconnect and restraining device			

Marshall Air Systems, Inc.

419 Peachtree Drive South • Charlotte, North Carolina 28217 USA • Phone: (704) 525-6230 Fax: (704) 525-6229 • www.marshallair.com