



Autotoast™

Model HT18

High Speed Horizontal Contact Toaster

Item No: _____

AIA FILE NO. / SPEC NO.
CONSULTANT/ CONTRACTOR APPROVAL



Model HT18

The Marshall **Model HT18** Horizontal Contact Toaster produces 160° F caramelized buns quickly with or without butter. This compact model is so fast it can produce 1800 4" hot buns in one hour with minimal moisture loss. Perfect for building sandwiches to customer orders. Buns are loaded in the front, face-up and return to the front. The variable speed drive ranges from 9 to 90 seconds. Heat controls are pre-set – no adjustment needed. Speed control is hidden, thus eliminating unauthorized tampering. The toaster has dual adjustments for various crown/heel thicknesses. Conveyor assembly is easily removed for cleaning.

All Marshall products are supported by a nationwide service organization and in-house, full-time Customer Support Department. To place an order call:

1-800-627-8368

**ETL (US, Canada) & NSF Listed
FOR COMMERCIAL USE ONLY**

Marshall's horizontal contact toaster is designed specifically for QSR, fast casual restaurants, sandwich shops, cafeterias, snack bars and convenience stores using dry or pre-buttered bread products.

FEATURES

- Toasts to 160° F quickly
- Accommodates dry or buttered buns
- Easy to operate control panel
- Adjustable for different bun thickness
- Variable speed
- Heavy duty, long life conveyor belt
- Removable conveyor for daily cleaning
- Removable slip sheets for ease of cleaning
- Uses small electrical circuit (20 amp)

CONSTRUCTION

- Heavy gauge stainless steel frame
- Solid weld frame construction
- Large bearings for longer life
- Plug-in motor and solid-state speed control
- Heavy-duty drive system

VOLUME

Bun Peak Production:

1080 5" buns per hour
1800 4" buns per hour

(Figures for estimating only. Actual production can be calculated with food specifics.)

**Ask about Marshall's ThermoGlo Food Warmers, companion Conveyor Broilers and Ventilation Systems.*

Marshall Air Systems, Inc.

419 Peachtree Drive South • Charlotte, North Carolina 28217 USA • Phone: (704) 525-6230 Fax: (704) 525-6229 • www.marshallair.com



Autotoast™

Model HT18

Horizontal Contact Toaster

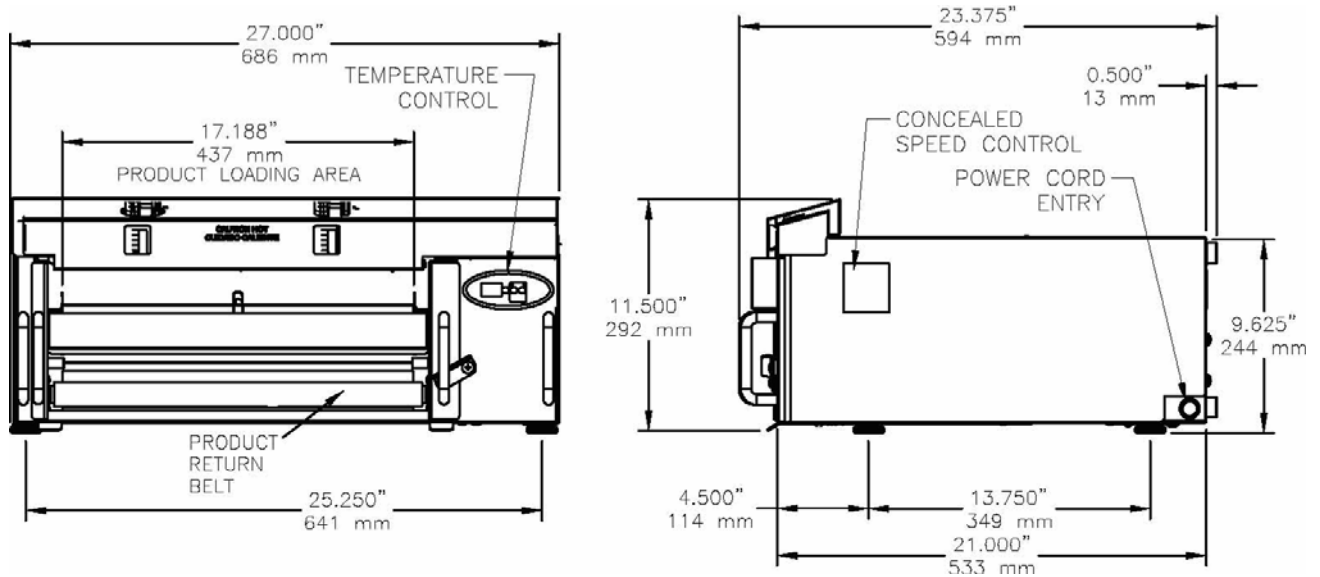

Overall Dimensions Model HT18

Dimensions:	Height: 11.50" 292mm	Width: 27.00" 686mm	Depth: 23.375" 594mm	
Shipping Information:	Weight: Net 85 lbs. 39 kilos	Ship Wt: 110 lbs. 50 kilos	NMFC #26500 Freight (USA) Class 70	Ship. Cubes: 15 cubic ft. 0.43 cubic meters
Electrical:	208V/60Hz/1 ph 16 amps NEMA 6-20 Plug	or	240V/60Hz/1 ph 19 amps NEMA 6-20 Plug (Domestic Units only)	
Gas Supply:	None			
Options:	Other electrical configurations			

Marshall Air Systems, Inc.

419 Peachtree Drive South • Charlotte, North Carolina 28217 USA • Phone: (704) 525-6230 Fax: (704) 525-6229 • www.marshallair.com