



# Heated Sandwich Wrap Table

Item No: \_\_\_\_\_

AIA FILE NO. / SPEC NO.

CONSULTANT/ CONTRACTOR APPROVAL



Model 146651 Shown

The Marshall **Heated Sandwich Wrap Table** top surface provides a uniform heat surface side to side and keeps food warm during preparation.

The Heated Sandwich Wrap Table has no bulbs, lamps or tubes to burn out. The gently warmed preparation surface assists in keeping food products warm while being prepared.

All Marshall products are supported by a nationwide service organization and an in-house, full-time Customer Support Department. To place an order, call:

**1-800-627-8368**

**ETL (US & Canada) & NSF Listed  
FOR COMMERCIAL USE ONLY**

*Ask about Marshall's companion High Speed Toasters, Conveyor Broilers, Heated Holding Cabinets and Ventilation Systems.*

## FEATURES

- Heat is distributed uniformly across table surface to assist in keeping food products warm during preparation
- Extremely durable metal heating surface is encased in a tough stainless steel housing. There are no fragile exposed bulbs or tubes to chip or break... or fall into food
- Heated Sandwich Wrap Tables carry a full 1-year repair or replacement guarantee
- Lockable casters are standard on one side and bullet feet on opposite side, enabling table to move easily for cleaning but remain stationary during use
- Drop down shelf accommodates industry standard warming units
- Cutout in top will accommodate a 1/3 size pan (pan not included)
- Two lower storage shelves for boxes, baskets, wrapping supplies and more
- All welded construction for stability and long life
- Universal control box location
- Available in four different lengths to fit your kitchen size

---

### Marshall Air Systems, Inc.

419 Peachtree Drive South • Charlotte, North Carolina 28217 USA • Phone: (704) 525-6230 Fax: (704) 525-6229 • [www.marshallair.com](http://www.marshallair.com)



# Heated Sandwich Wrap Table

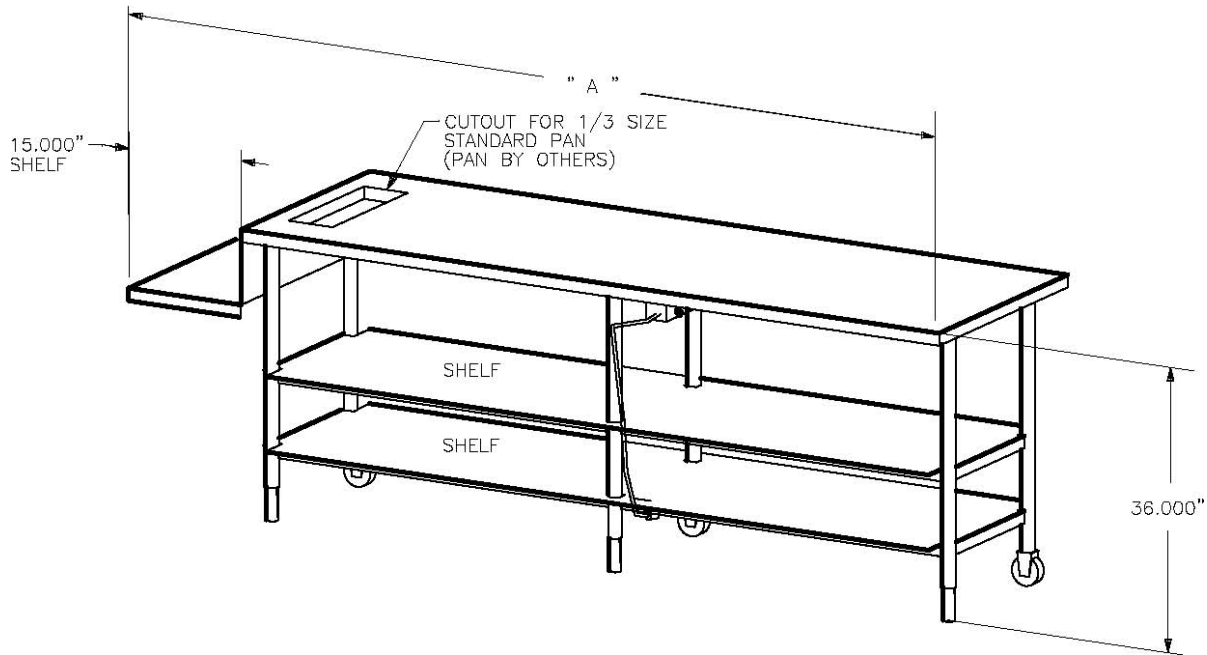

<b>Dimensions:</b>		<b>"A" Width:</b>	<b>Depth:</b>
Model:	147951	87"	30"
	146651	108"	30"
	152398	128"	30"
	152150	141"	30"

<b>Shipping Information:</b>		<b>Weight:</b>	<b>Ship W:</b>	<b>NMFC 62220 Freight (USA):</b>	<b>Ship. Cubes:</b>
Model:	147951	325 lbs.	375 lbs.	Class 100	92 cu. ft.
	146651	410 lbs.	461 lbs.	Class 100	110 cu. ft.
	152398	480 lbs.	534 lbs.	Class 100	132 cu. ft.
	152150	525 lbs.	590 lbs.	Class 100	142 cu. ft.

<b>Electrical Wiring:</b>		<b>Model:</b>	<b>120/60Hz/1ph</b>	<b>amps</b>	<b>Plug</b>
Model:	147951	120/60Hz/1ph	1.2 amps	L1, N, G, 8 ft. cord, NEMA 5-15 Plug	
	146651	120/60Hz/1ph	2.1 amps	L1, N, G, 8 ft. cord, NEMA 5-15 Plug	
	152398	120/60Hz/1ph	2.6 amps	L1, N, G, 8 ft. cord, NEMA 5-15 Plug	
	152150	120/60Hz/1ph	3.0 amps	L1, N, G, 8 ft. cord, NEMA 5-15 Plug	

**Marshall Air Systems, Inc.**  
 419 Peachtree Drive South • Charlotte, North Carolina 28217 USA • Phone: (704) 525-6230 Fax: (704) 525-6229 • www.marshallair.com