



ThermoGlo™

Models KK6, AT1, AV1 Multi-Product Holding Unit

Item No: _____

AIA FILE NO. / SPEC NO.

CONSULTANT / CONTRACTOR APPROVAL



Model KK6

The Marshall **Model KK6, AT1, AV1** Multi-Product Holding Units feature our ThermoGlo™ heating technology. Heat radiates from every square inch of the upper and lower flat plate surfaces. This eliminates the need to clean intricate calrod, wire and reflector assemblies.

The **Models KK6, AT1 and AV1** are designed to accommodate a full size (12"x 20") steam table pan. The **Model KK6** has swing-out Lexan® doors on three sides prevent drafts from cooling food items and allow easy access. The sloped bottom design of the KK6 displays your food product from countertop surfaces. A precision digital display and digital "set point" temperature controller maintain consistent product temperature.

All Marshall products are supported by a nationwide service organization and in-house, full-time Customer Support Department. To place an order call:

1-800-627-8368

**ETL (US & Canada) & NSF Listed
FOR COMMERCIAL USE ONLY**

Marshall's Multi-Product Holding Unit features ThermoGlo™ technology designed to solve demanding food warming and holding requirements.

FEATURES

- Microprocessor controls exact heat intensity to furnish a specific temperature
- Delivers a wide range of temperature capabilities to fill exact warming and holding requirements
- Flat surface allows for easy wipe-clean application
- Food stays "presentation ready" longer because exact internal temperatures can be reached faster and maintained longer
- Stacking kit option allows double capacity in the same table space
- Illumination provided by (2) 40-watt food grade coated bulbs

CONSTRUCTION

- Heavy gauge stainless steel
- Designed and built to custom specifications with heat radiating from the ThermoGlo™ surfaces
- Designed with a flat unbreakable heat radiating metal face encased in stainless steel housing
- Tough Lexan® doors on three sides prevent drafts (KK6 Model only)

**Ask about Marshall's companion High Speed Toasters, Conveyor Broilers and Ventilation Systems.*

Marshall Air Systems, Inc.

419 Peachtree Drive South • Charlotte, North Carolina 28217 USA • Phone: (704) 525-6230 Fax: (704) 525-6229 • www.marshallair.com



ThermoGlo™

Models KK6, AT1, AV1
Multi-Product Holding Unit

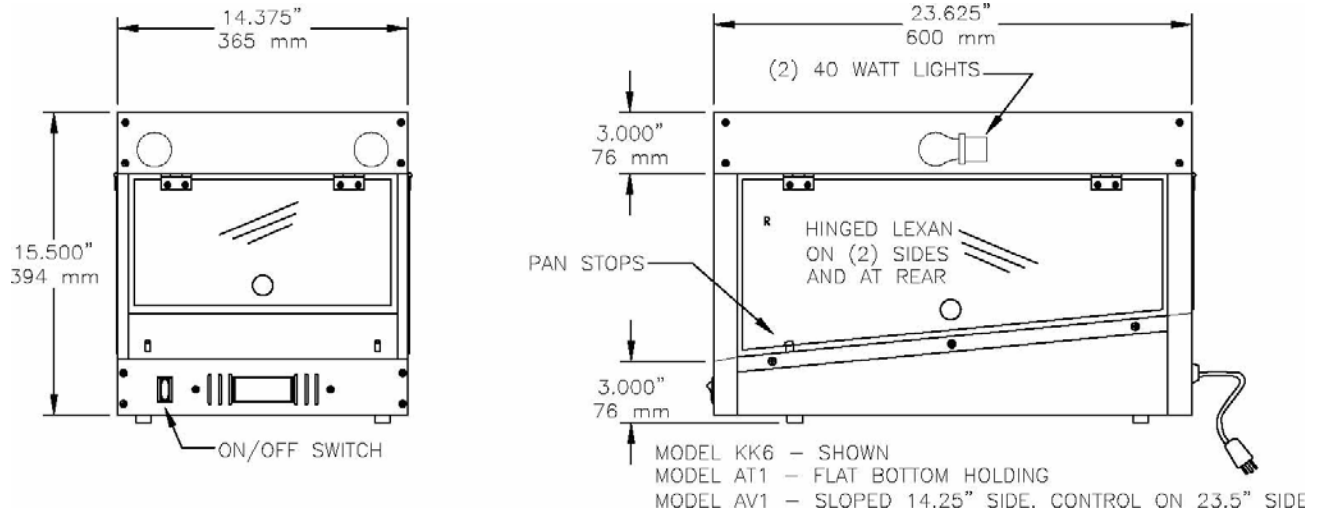

Overall Dimensions Models KK6, AT1, AV1

Dimensions:	Height: 15.500" (394mm)	Width: 14.375" (365mm)	Depth: 23.625" (600mm)	
Shipping Information:	Weight: Net 48 lbs. (22 kilos)	Ship Wt: 53 lbs. (24 kilos)	Freight (USA): NMFC Class 100	Ship. Cubes: 3.8 cubic ft. 11 cubic meters
Electrical Wiring:	120/60Hz/1ph – 5.5 amps NEMA 5-15 Plug 6 ft. cord	or	220-240V/50Hz/1ph – 3amps (Intl) L1, N, G 6 ft. cord without plug	
Options:	Stacking Kit			

Marshall Air Systems, Inc.

419 Peachtree Drive South • Charlotte, North Carolina 28217 USA • Phone: (704) 525-6230 Fax: (704) 525-6229 • www.marshallair.com