



ThermoGlo™

Model MM1 Series Heat Station

Item No: _____

AIA FILE NO. / SPEC NO.

CONSULTANT / CONTRACTOR APPROVAL



Model MM1

The Marshall **Model MM1 Series** features our ThermoGlo™ heating technology. Heat radiates from every square inch of the upper flat plate surface. This eliminates the need to clean intricate calrod, wire and reflector assemblies. An accessory 120 V receptacle at the back is ideal for powering a timer. This receptacle is furnished only on **Model MM1**. **Model MM1E** is the high-intensity heat version, while the **Model MM1D** is the half-size version.

In addition to french fries, this holding unit can be used for a variety of other fried foods such as wings, chicken, hush puppies, onion rings and more.

All Marshall products are supported by a nationwide service organization and in-house, full-time Customer Support Department. To place an order call:

1-800-627-8368

Marshall's most popular french fry holding unit features ThermoGlo™ technology. This unit can also be used for holding and warming a wide variety of foods.

FEATURES

- Even heat eliminates hot and cold spots
- Holds full size 12" x 20" steam table pan (not included.) MM1D holds ½ size pan (not included.)
- Flat surface allows for easy wipe-clean maintenance
- Food stays “presentation ready” longer because exact internal temperatures can be reached faster and maintained longer

CONSTRUCTION

- Heavy gauge stainless steel
- Designed and built to custom specifications with heat radiating from the ThermoGlo™ surface
- Designed with a flat unbreakable radiating metal face encased in stainless steel housing

ETL (US & Canada) & NSF Listed FOR COMMERCIAL USE ONLY

**Ask about Marshall's companion High Speed Toasters, Conveyor Broilers and Ventilation Systems.*

Marshall Air Systems, Inc.

419 Peachtree Drive South • Charlotte, North Carolina 28217 USA • Phone: (704) 525-6230 Fax: (704) 525-6229 • www.marshallair.com



ThermoGlo™

Model MM1 Series Heat Station

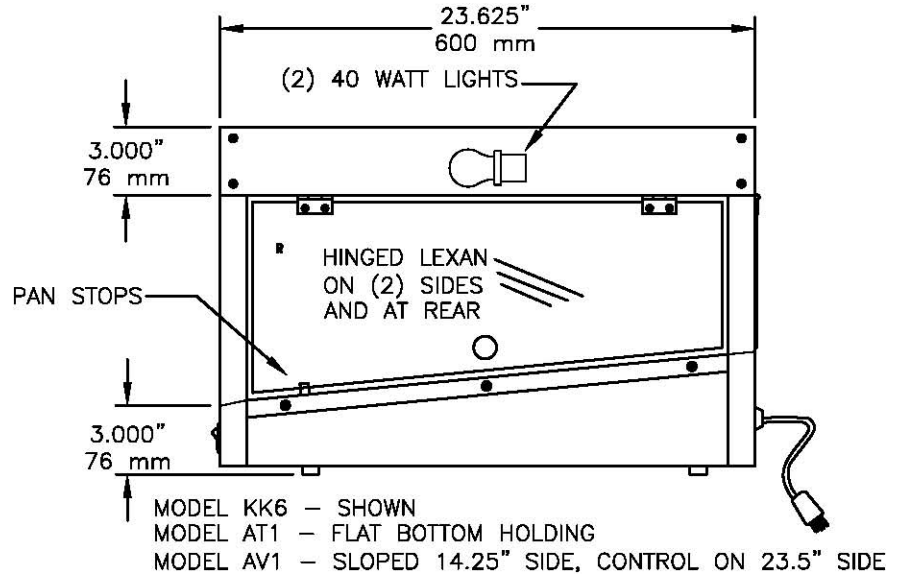
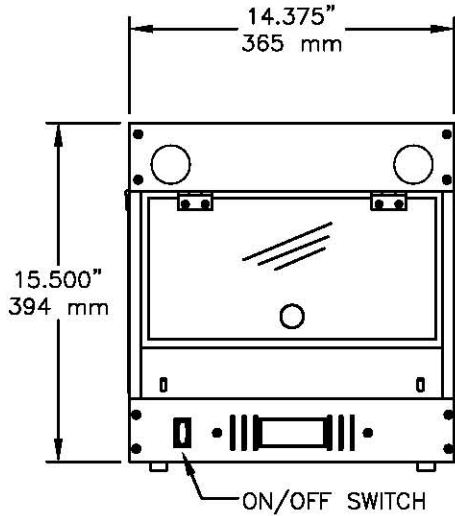

Overall Dimensions Model MM1 Series

Dimensions:	Height:	Width:	Depth:
MM1 / MM1C/ MM1E	19.875" (504 mm)	13.000" (330 mm)	24.125" (613 mm)
MM1D	19.250" (489 mm)	13.000" (330 mm)	13.625" (346 mm)
Shipping Information:	Weight:	Ship Wt:	Freight (USA): Ship. Cubes:
	Net 22 lbs. (10 kilos)	28 lbs. (13 kilos)	NMFC 5 cubic ft. Class 100 .14 cubic meters
Electrical			
MM1	120V/ 50/60 Hz/ 7 amps/ 0.84 kw and 5 amps/ 0.6 kw	or	220-240V/50Hz/1 ph 4 amps (Intl)/ 0.88-0.96 kw
MM1D	120V/ 50/60 Hz/ 4 amps/ 0.48 kw		
MM1E	120V/ 50/60 Hz/ 8.3 amps/ 0.996 kw		
Gas Supply:	None		
Options:	None		

Marshall Air Systems, Inc.

419 Peachtree Drive South • Charlotte, North Carolina 28217 USA • Phone: (704) 525-6230 Fax: (704) 525-6229 • www.marshallair.com