



# Autotoast™

Model VT12

## High Speed Vertical Contact Toaster

Item No: \_\_\_\_\_

AIA FILE NO. / SPEC NO.

CONSULTANT/ CONTRACTOR APPROVAL



Model VT12

Marshall's **Model VT12** High Speed Vertical Toaster is designed to toast buns faster and hotter. A combination of conduction, convection and infrared heating, built into this unit, toasts buns in 16 to 20 seconds, depending on bun size. Internal product temperatures range up to 160°F.

The **Model VT12** toaster is equipped with a self-adjusting, spring-loaded bun compression system. This system achieves consistent results with extra thick or thin buns.

All Marshall products are supported by a nationwide service organization and in-house, full-time Customer Support Department. To place an order call:

**1-800-627-8368**

**ETL (US, Canada) & NSF Listed  
FOR COMMERCIAL USE ONLY**

**Marshall's high-speed vertical toaster is designed specifically for QSR, fast casual restaurants, sandwich shops, cafeterias, snack bars and convenience stores.**

### FEATURES

- Toasts to 160° F in just 16 seconds
- Easy to operate control panel
- Adjustable for different bun thickness
- Variable speed
- Heavy duty, long life belts
- Removable slip sheets for ease of cleaning
- Many parts are interchangeable with Marshall's Autobroil™, which simplifies maintenance

### CONSTRUCTION

- Heavy gauge stainless steel frame
- Solid weld frame construction
- Large bearings for longer life
- Plug-in motor and solid-state speed control
- Heavy-duty drive system

### VOLUME

#### **Bun Peak Production:**

1,150 4½" buns per hour

*(Figures for estimating only. Actual production can be calculated with food specifics.)*

*\*Ask about Marshall's ThermoGlo Food Warmers, companion Conveyor Broilers and Ventilation Systems.*

---

### Marshall Air Systems, Inc.

419 Peachtree Drive South • Charlotte, North Carolina 28217 USA • Phone: (704) 525-6230 Fax: (704) 525-6229 • www.marshallair.com

Printed in U.S.A. © Marshall Air Systems, Inc. 2007 All rights reserved.

Marshall's commitment to quality and product improvement may change specifications from time to time.

Rev041609



# Autotoast™

## Model VT12

### High Speed Vertical Toaster

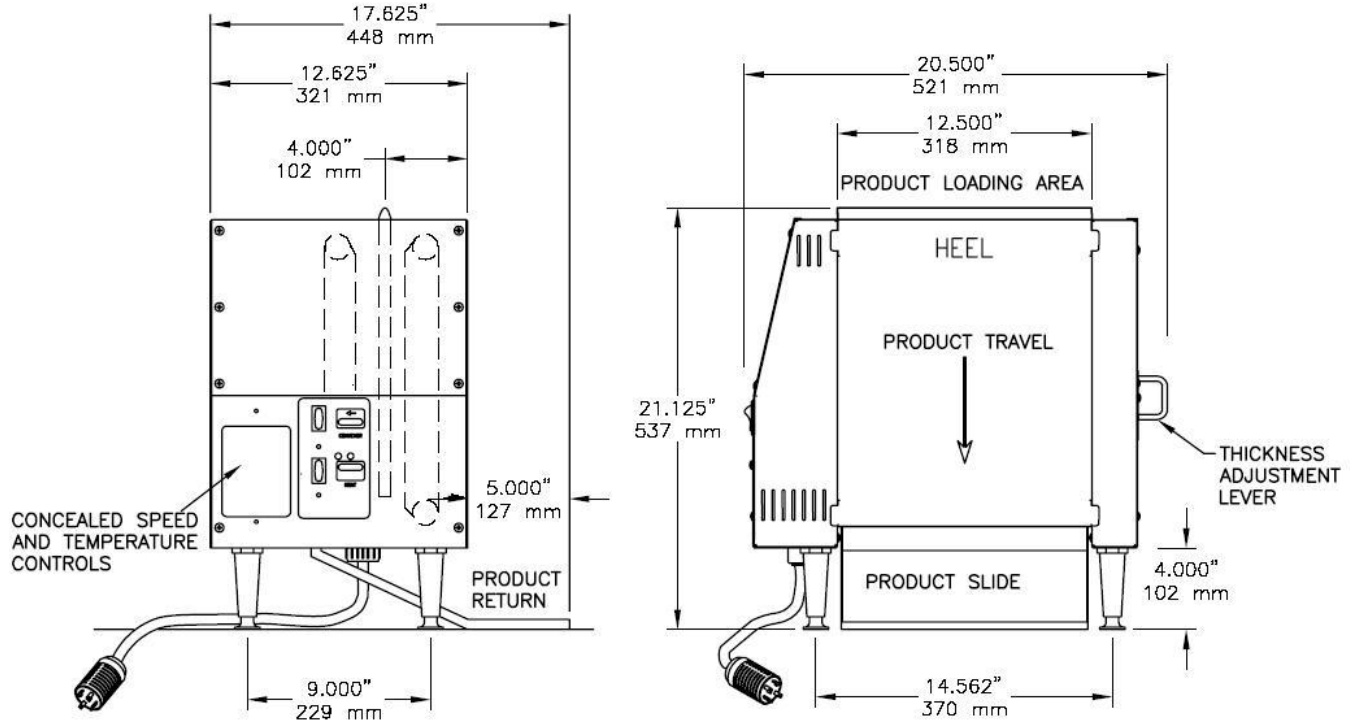

### Overall Dimensions Model VT12

Dimensions:	Height: 21.125" 537mm	Width: 20.500" 521mm	Depth: 17.625" 448mm	
Shipping Information:	Weight: Net 62 lbs. 29 kilos	Ship Wt: 72 lbs. 33 kilos	Freight (USA): NMFC Class 100	Ship. Cubes: 7 cubic ft 0.2 cubic meters
Electrical Wiring:	208-240V/60Hz/1 ph – 21amps or			240V/50Hz/1 ph–23amps (Intl)
	L1,L2,N,G 6 Ft. cord NEMA L14-30P Plug			L1, N, G 6 Ft. cord without plug
Gas Supply:	None			
Options:	None			

### Marshall Air Systems, Inc.

419 Peachtree Drive South • Charlotte, North Carolina 28217 USA • Phone: (704) 525-6230 Fax: (704) 525-6229 • www.marshallair.com