



Autotoast™

Model VT18

High Speed Vertical Contact Toaster

Item No: _____

AIA FILE NO. / SPEC NO.

CONSULTANT/ CONTRACTOR APPROVAL



Model VT18

The Marshall **Model VT18** Vertical Toaster produces 160° F caramelized buns quickly with or without butter. This compact model is so fast it can produce 1800 4" hot buns in one hour with minimal moisture loss. Perfect for building sandwiches to customer orders. Buns are loaded at the top and released onto a product slide at the bottom. The variable speed drive ranges from 20 seconds to 2 minutes. Heat controls are fully adjustable from 200°-565°F. Left and right side toasting temperatures can be zoned for flexibility.

Speed controls are located inside a secured cabinet, eliminating unauthorized tampering. The toaster is adjustable for various crown and heel bread thicknesses. The multi-control feature options of this toaster produce and deliver the hottest buns in the shortest time.

All Marshall products are supported by a nationwide service organization and in-house, full-time Customer Support Department. To place an order call:

1-800-627-8368

**ETL (US, Canada) & NSF Listed
FOR COMMERCIAL USE ONLY**

Marshall's vertical contact toaster is designed specifically for QSR, fast casual restaurants, sandwich shops, cafeterias, snack bars and convenience stores using dry or pre-buttered bread products.

FEATURES

- Toasts to 160° F quickly
- Accommodates dry or buttered buns
- Easy to operate control panel
- Adjustable for different bun thickness
- Variable speed
- Heavy duty, long life conveyor belt
- Removable conveyor for daily cleaning
- Removable slip sheets for ease of cleaning
- Uses small electrical circuit (20 amp)

CONSTRUCTION

- Heavy gauge stainless steel frame
- Solid weld frame construction
- Large bearings for longer life
- Plug-in motor and solid-state speed control
- Heavy-duty drive system

VOLUME

Bun Peak Production:

- 1,080 5" buns per hour
- 1,800 4" buns per hour (no markings)

(Figures for estimating only. Actual production can be calculated with food specifics.)

**Ask about Marshall's ThermoGlo Food Warmers, companion Conveyor Broilers and Ventilation Systems.*

Marshall Air Systems, Inc.

419 Peachtree Drive South • Charlotte, North Carolina 28217 USA • Phone: (704) 525-6230 Fax: (704) 525-6229 • www.marshallair.com



Autotoast™

Model VT18

High Speed Vertical Contact Toaster

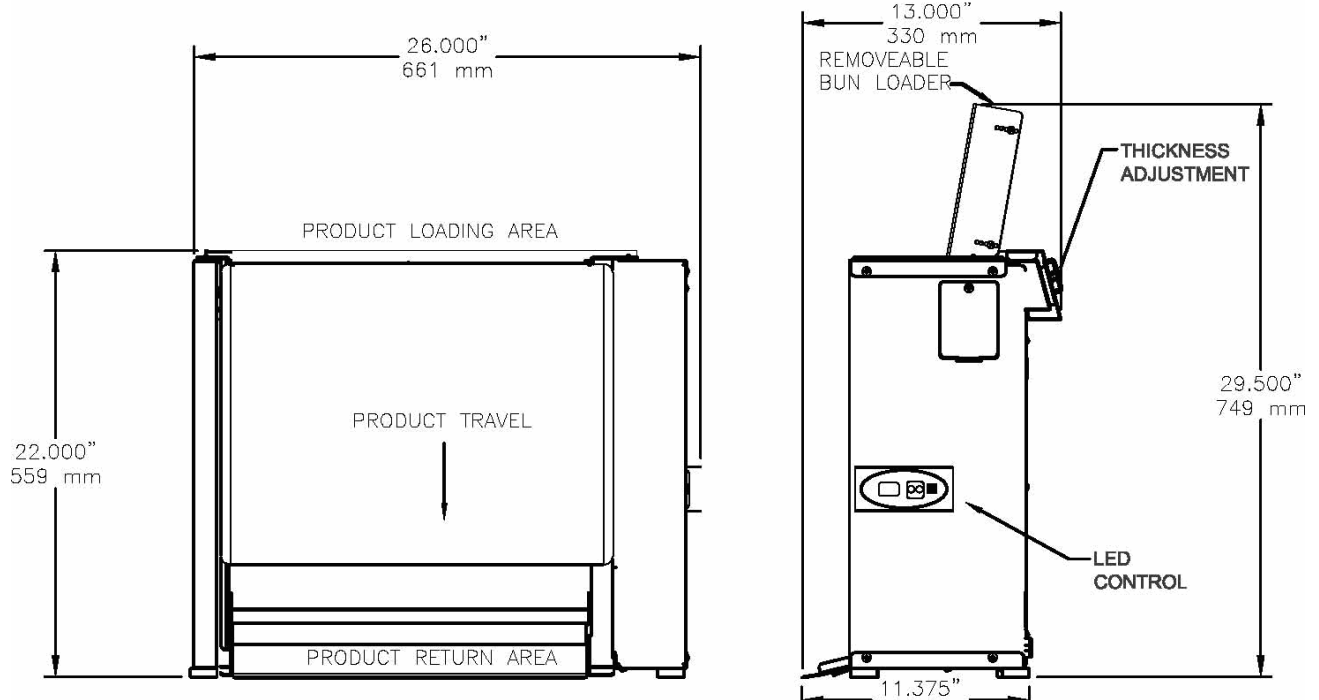

Overall Dimensions Model VT18

Dimensions:	Height: 22.000" 559mm	Height w/Loader: 29.500" 749mm	Width: 26.000" 661mm	Depth: 13.000" 330mm
Shipping Information:	Weight: Net 103 lbs. 47 kilos	Ship Wt: 125 lbs. 57 kilos	NMFC #26500 Freight (USA) Class 70	Ship Cubes: 15 cubic ft. 0.43 cubic meters
Electrical: Wiring:	208V/60Hz/1 ph 16 amps NEMA 6-20 Plug	or	240V/60Hz/1 ph 19 amps NEMA 6-20 Plug (Domestic Units only)	
Gas Supply:	None			
Options:	Other electrical configurations			

Marshall Air Systems, Inc.

419 Peachtree Drive South • Charlotte, North Carolina 28217 USA • Phone: (704) 525-6230 Fax: (704) 525-6229 • www.marshallair.com